

GLASSLINED & GALVANIZED PUMP TANK

- **Safety Instructions**
- **Installation**
- **Operation**
- **Warranty**

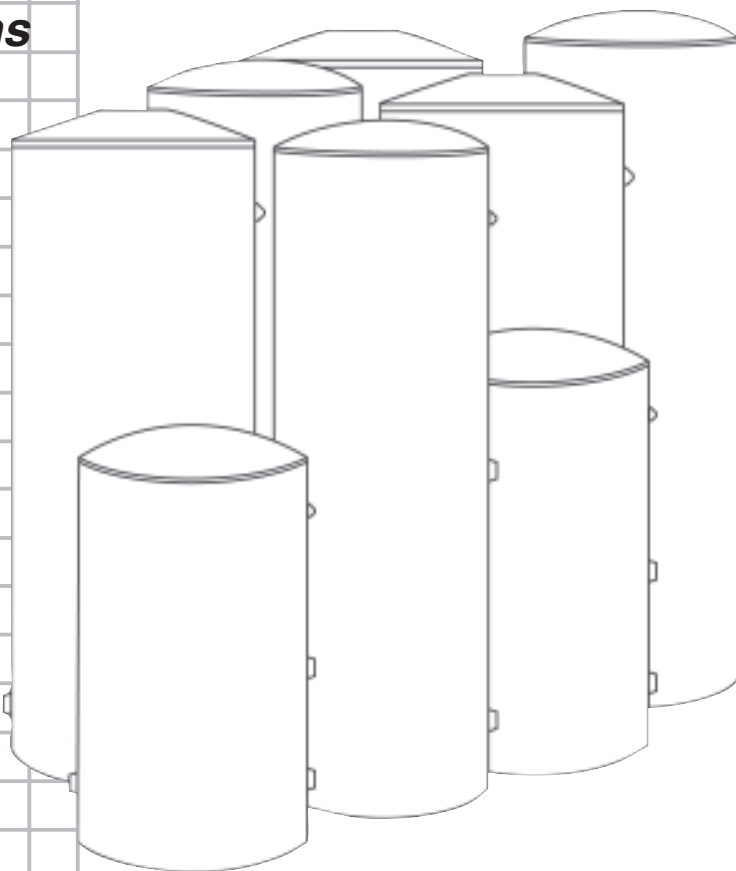

NATIONAL SANITATION FOUNDATION

	⚠ WARNING
	Read and understand instruction manual and safety messages before installing, operating or servicing this pump tank.
	Failure to follow instructions and safety messages could result in death or serious injury.

Owner's Manual must remain with pump tank.

Thank You for purchasing a pump tank. Properly installed and maintained, it should give you years of trouble free service. If you should decide that you want the new water tank professionally installed, contact a local professional installer.

ALL TECHNICAL AND WARRANTY QUESTIONS: SHOULD BE DIRECTED TO THE LOCAL DEALER FROM WHOM THE PUMP TANK WAS PURCHASED. IF YOU ARE UNSUCCESSFUL, PLEASE WRITE TO THE COMPANY LISTED ON THE RATING PLATE ON THE PUMP TANK.



KEEP THIS MANUAL FOR FUTURE REFERENCE WHENEVER MAINTENANCE ADJUSTMENT OR SERVICE IS REQUIRED.

SAFE INSTALLATION USE AND SERVICE

Your safety and the safety of others is extremely important in the installation, use and servicing of this pump tank.

Many safety-related messages and instructions have been provided in this manual and on your own pump tank to warn you and others of a potential injury hazard. Read and obey all safety messages and instructions throughout this manual. It is very important that the meaning of each safety message is understood by you and others who install, use or service this water tank.

	This is the safety alert symbol. It is used to alert you to potential personal injury hazards. Obey all safety messages that follow this symbol to avoid possible injury or death.
---	--

	DANGER indicates an imminently hazardous situation which, if not avoided, could result in death or injury.
	WARNING indicates a potentially hazardous situation which, if not avoided, could result in death or injury.
	CAUTION indicates a potentially hazardous situation which, if not avoided, may result in minor or moderate injury.

All safety messages will generally tell you about the type of hazard, what can happen if you do not follow the safety message and how to avoid the risk of injury.

RULES FOR SAFE INSTALLATION AND OPERATION

1. Read these Rules and Instructions carefully. Failure to follow them could cause serious bodily injury and/or property damage.
2. Be sure installation meets all local plumbing, pump, electrical and well codes.
3. Always test water from well for purity before using. Call your local health department for testing procedure.
4. Before installing or servicing your pump, BE SURE pump power source is disconnected.

IMPORTANT DEFINITION:

NSF (National Sanitation Foundation) - NSF International is The Public Health and Safety Company™, providing public health and safety risk management solutions to companies, governments and consumers around the world.

SAFETY PRECAUTIONS

WARNING

Improper installation, adjustment, alteration, service or maintenance can cause death, serious bodily injury or property damage. Refer to this manual for further assistance.

WARNING

This water tank is designed and intended for cold (ambient temperature) water storage at a maximum pressure of 75 PSIG, any use other than with cold water, or at a sustained or instantaneous pressure in excess of 75 PSIG is unsafe. A pressure relief valve of adequate size must be incorporated in the system. The relief valve must be selected to pass the full capacity of the pump when the pressure in this tank is 75 PSIG or less. Consult pump manufacturer for pump capacity at relief pressure. The manufacturer of this tank does not accept any liability or other responsibility for personal injury or property damage resulting from improper use, installation, or operation of this tank, or of the system of which it is a part.

DANGER

Failure to follow these instructions can cause tank to blow-up and result in death, serious bodily injury or property damage.

Install a 75 PSI or less pressure relief valve directly into a fitting of the plumbing. Position the valve downward and provide tubing so that any discharge will exit only within 6 inches above, or at any distance below the structural floor. Be certain that no contact is made with any live electrical part. The discharge opening must not be blocked or reduced in size under any circumstances. Excessive length, over 30 feet, or use of more than four elbows

can cause restriction and reduce the discharge capacity of the valve.

No valve or other obstruction is to be placed between the relief valve and the tank. Do not connect tubing directly to discharge drain unless a 6" air gap is provided. To prevent bodily injury, hazard to life, or property damage, the relief valve must be allowed to discharge water in quantities should circumstances demand. If the discharge pipe is not connected to a drain or other suitable means, the water flow may cause property damage.

The Discharge Pipe:

- Must not be smaller in size than the outlet pipe size of the valve, or have any reducing couplings or other restriction.
- Must not be plugged or blocked.
- Must be installed so as to allow complete drainage of both the pressure relief valve, and the discharge pipe.
- Must not have any valve between the relief valve and tank.

WARNING

Review the Installation Check List before turning on electric power to safeguard against possible dangerous malfunction of the pump tank.

WARNING

The complete pump, tank, pressure relief valve, pressure switch and piping system **MUST** be protected against below freezing temperature. Failure to do so could cause tank to blow-up and result in death, serious bodily injury or property damage.

TABLE OF CONTENTS

SAFE INSTALLATION USE AND SERVICE	2
SAFETY PRECAUTIONS	3
TABLE OF CONTENTS	3
PREPARING FOR NEW INSTALLATION	4
MATERIALS AND BASIC TOOLS NEEDED	4
Materials	4
Basic Tools	4
REMOVING THE OLD PUMP TANK	4
LOCATING THE NEW PUMP TANK	5
Facts to Consider About the Location	5
INSTALLING THE NEW PUMP TANK	5-7
Water Piping	5
Jet Pump (Shallow or Deep Well) Typical Installation	5
Submersible Pump Typical Installation	6
Optional Installation (Shallow or Deep Well)	6
Pressure Relief Valve	7
Filling the Pump Tank	7
Installation Checklist	7
FOR YOUR INFORMATION	7-8
Operational Conditions	7
How Pump Tanks Operate	7
Water Logged Condition	8
PERIODIC MAINTENANCE	8
Pressure Relief Valve Operation	8
Service	8
WARRANTY	10-11

PREPARING FOR NEW INSTALLATION

1. Read the “Safety Precautions” section, page 3 of this manual first and then the entire manual carefully. If you don’t follow the safety rules, the pump tank will not operate properly. It could cause death, serious bodily injury or property damage.

This manual contains instructions for the installation, operation, and maintenance of this pump tank. It also contains warnings throughout the manual that you must read and be aware of. All warnings and all instructions are essential to the proper operation of the pump tank and your safety. Since we cannot put everything on the first few pages, **READ THIS ENTIRE MANUAL BEFORE ATTEMPTING TO INSTALL OR OPERATE THE PUMP TANK.**

2. If after reading this manual you have any questions or do not understand any portion of the instructions, call a local plumbing contractor.

3. The installation must conform with the instructions in this manual; local plumbing, pump, and well codes and electric utility requirements.

4. Carefully plan the place where you are going to put the pump tank. Correct connections are very important in preventing death from possible electrical shock and fires. Examine the location to ensure the pump tank complies with the “Locating the New Pump Tank” section.

5. The pump tank must be located in an area not subject to freezing. Failure to do so voids the warranty.

WARNING

The complete pump, tank, pressure relief valve, pressure switch and piping system **MUST** be protected against below freezing temperature. Failure to do so could cause tank to blow-up and result in death, serious bodily injury or property damage.

WARNING

This water storage tank is designed for operation on cold well water systems limited to a maximum working pressure of 75 pounds per square inch (PSI).

WARNING

A pressure relief valve of adequate size must be incorporated in the system. The relief valve must be selected to pass the full capacity of the pump when the pressure in this tank is 75 PSI or less. Failure to follow these instructions can cause tank to blow-up and result in death, serious bodily injury or property damage.

6. Always test water from well for purity before using. Check your local health department for testing procedure.

7. Review the “Installation Checklist” in the “Installing the New Pump Tank” section before turning “ON” electric power to the pump to safeguard against possible dangerous malfunction of the water tank.

MATERIALS AND BASIC TOOLS NEEDED

Materials Needed

You may or may not need all of these materials, depending on your type of installation.

PLASTIC PIPE INSTALLATION

- Plastic Pipe and Fittings (as required to complete the job).
- Teflon Tape (DO NOT use pipe joint compound on plastic fittings).

GALVANIZED STEEL PIPE INSTALLATION

- Galvanized Pipe and Fittings (as required to complete the job).
- Pipe Joint Compound or Teflon Tape.

Basic Tools

You may or may not need all of these tools, depending on your type of installation. These tools can be purchased at your local hardware store.

PLASTIC PIPE INSTALLATION

- Pipe Wrenches
- Screwdriver
- Knife or Saw to Cut Plastic Pipe

GALVANIZED STEEL PIPE INSTALLATION

- Pipe Wrenches
- Screwdriver
- Pipe Cutting and Threading Tools

REMOVING THE OLD PUMP TANK

1. Turn “OFF” electrical supply to the pump at the fuse or circuit breaker box.

WARNING

HAZARD OF ELECTRICAL SHOCK! Failure to turn “OFF” electric power to the pump will result in the possibility of death, serious bodily injury, or property damage.

2. Turn “OFF” the water supply between the pump tank and house. In the event this is not possible, the water heater must be turned

off and drained. Refer to the water heater manual for this procedure.

3. Connect a hose to a drain valve in the piping system, run the end of the hose to an adequate drain, and drain the pump tank.

4. When the pump tank is drained, remove the hose and close the drain valve. Disconnect and remove the old pump tank.

LOCATING THE NEW PUMP TANK

Facts to Consider About the Location

You should carefully choose an indoor location for the new pump tank. This pump tank is not intended for outdoor installation and is rated for cold water storage only.

Whether replacing an old pump tank or putting the pump tank in a new location, the following critical points must be observed.

1. The location selected should be indoors as close to and as centralized with the water piping system as possible.
2. The pump tank must be located in an area not subject to freezing. Failure to do so voids the warranty.

WARNING

The complete pump, tank, pressure relief valve, pressure switch

and piping system MUST be protected against below freezing temperature. Failure to do so could cause tank to blow-up and result in death, serious bodily injury or property damage.

3. This pump tank, as all pump tanks, will eventually leak. Do not install without adequate drainage provisions where water flow will cause damage.

CAUTION

The installation of the pump tank must be accomplished in such a manner that if the tank or any connections should leak, the flow of water will not cause damage to the area adjoining the pump tank, or to the lower floors of the structure.

4. The location selection must provide adequate clearances for servicing and proper operation of the pump tank.

INSTALLING THE NEW PUMP TANK

Water Piping

Remove plastic plugs in all fittings of the pump tank. The illustrations in figures 1–3 show the correct valves and fittings that you will need to install your pump tank according to your type of pump. Install the pump tank according to the pump installation.

IMPORTANT: DO NOT use any type of lubricant other than water

on hose and plastic fittings. Do not connect brass fittings to galvanized fittings unless a dielectric union is placed between connections.

When pump and tank are in different locations, the pressure switch should be at the tank location. Or compensating adjustment must be made for pressure loss due to head of water, i.e., one PSI for every two feet of elevation.

JET PUMP (Shallow or Deep Well) TYPICAL INSTALLATION

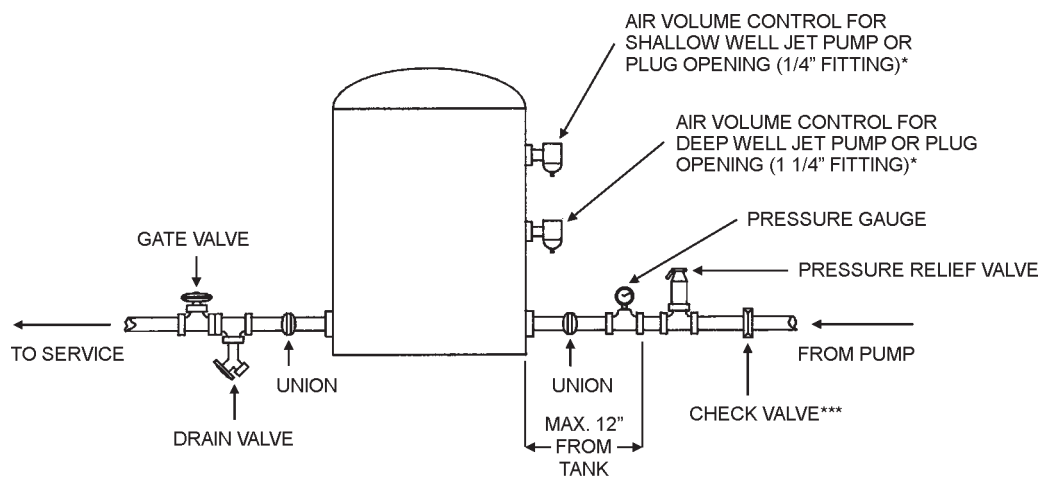

FIGURE 1

SUBMERSIBLE PUMP TYPICAL INSTALLATION

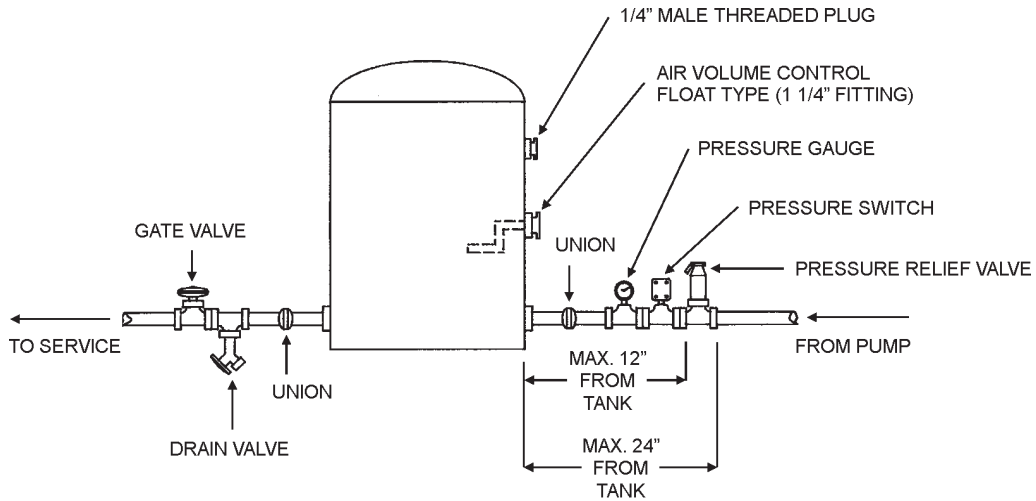

FIGURE 2

OPTIONAL INSTALLATION (Shallow or Deep Well) RECOMMENDED FOR NEW INSTALLATIONS

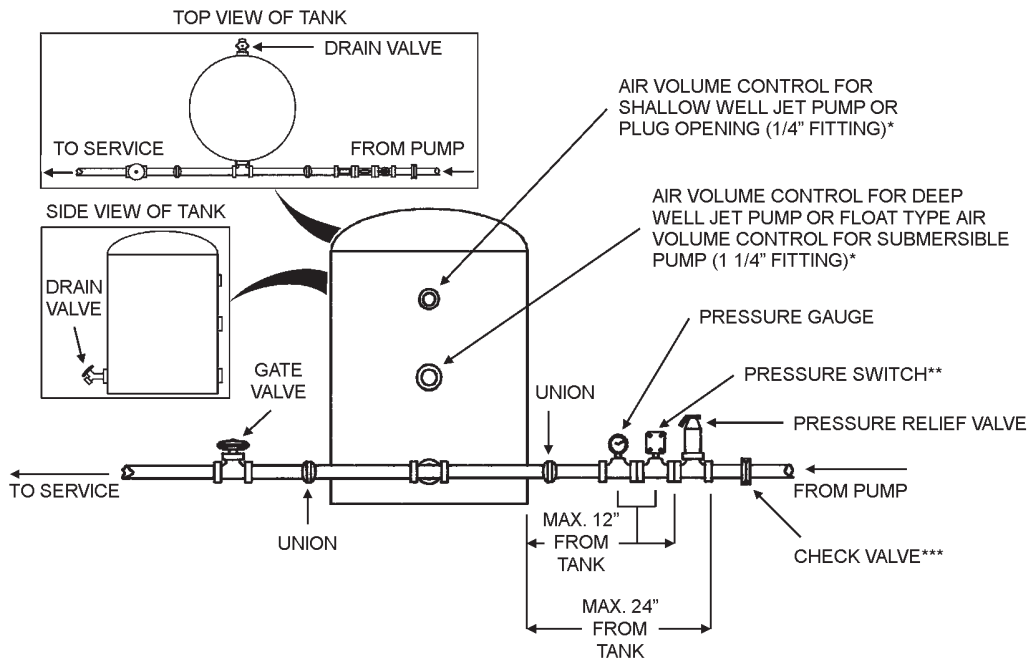

FIGURE 3

- NOTES:**
- *If air volume control not installed in this fitting, opening must be plugged using a male threaded plug of proper size.
 - ** OPTIONAL...MUST BE INSTALLED IF PUMP DOES NOT HAVE A PRESSURE SWITCH.
 - ***OPTIONAL...MUST BE INSTALLED IF PUMP DOES NOT HAVE A CHECK VALVE.

Pressure Relief Valve

WARNING

This pump tank is designed and intended for cold (ambient temperature) water storage at a maximum pressure of 75 PSIG, any use other than with cold water, or at a sustained or instantaneous pressure in excess of 75 PSIG is unsafe. A pressure relief valve of adequate size must be incorporated in the system. The relief valve must be selected to pass the full capacity of the pump when the pressure in this tank is 75 PSIG or less. Consult pump manufacturer for pump capacity at relief pressure. The manufacturer of this tank does not accept any liability or other responsibility for personal injury or property damage resulting from improper use, installation, or operation of this tank, or of the system of which it is a part.

Failure to follow these instructions can cause tank to blow-up and result in death, serious bodily injury or property damage.

Install a 75 PSI or less pressure relief valve directly into a fitting of the plumbing. Position the valve downward and provide tubing so that any discharge will exit only within 6 inches above, or at any distance below the structural floor. Be certain that no contact is made with any live electrical part. The discharge opening must not be blocked or reduced in size under any circumstances. Excessive length, over 30 feet, or use of more than four elbows can cause restriction and reduce the discharge capacity of the valve.

No valve or other obstruction is to be placed between the relief valve and the tank. Do not connect tubing directly to discharge drain unless a 6" air gap is provided. To prevent bodily injury, hazard to life, or damage property, the relief valve must be allowed to discharge water in quantities should circumstances demand. If the discharge pipe is not connected to a drain or other suitable means, the water flow may cause property damage.

The Discharge Pipe:

- Must not be smaller in size than the outlet pipe size of the valve, or have any reducing couplings or other restriction.

- Must not be plugged or blocked.
- Must be installed so as to allow complete drainage of both the pressure relief valve, and the discharge pipe.
- Must not have any valve between the relief valve and tank.

WARNING

Do not install a shutoff valve between the tank and the pressure relief valve. Failure to follow these instructions can cause the tank to blow-up and result in death, serious bodily injury, or property damage.

WARNING

Do not install a shutoff valve, plug or cap in your pressure relief valve drain line. Failure to follow these instructions can cause the tank to blow-up and result in death, serious bodily injury, or property damage.

Filling the Pump Tank

It will be necessary to expel all air from the piping after new installations, repriming and after the pump has been disassembled for repair. To purge the air, first open a faucet, the greatest distance from the pump. With the pump being allowed to run, wait until a steady stream of water is coming from the faucet. This will allow the pump tank to fill with water.

If after this, air in the lines still occurs, check on the suction side of the pump (piping to pump from well) for piping leaks.

Installation Checklist

1. Is the pressure relief valve installed correctly? See "Pressure Relief Valve" in the "Installing the New Pump Tank" section.
2. Will a water leak damage anything? See the "Locating the Pump Tank" section.
3. Is the pump tank and system filled with water? See "Filling the Pump Tank" in the "Installing the New Pump Tank" section.
4. Turn on electricity to the pump.

FOR YOUR INFORMATION

Operational Conditions

HOW PUMP TANKS OPERATE

For a tank to operate satisfactorily, it must be capable of storing a desired amount of water under pressure and permit a portion of this water to be drawn off before the pump has to start.

Water is non-compressible, therefore, if a tank were completely filled with water under pressure and a faucet was opened, the pressure would drop immediately.

Referring to the illustration in figure 4, the pump would start with the water level as shown in "A" and as water was pumped into the tank, the air would rise to the level shown in "B" and the pump would stop. When a faucet is opened, the compressed air,

acting like a spring, would force water out until the cut-in pressure is reached, The amount of water between the two points is called draw-off.

The amount of draw-off is dependent on the proportion of air and water in the tank to start with. This is controlled by the location of the air volume control and the "cut-in, cut-out" pressure of the system. The pump tanks are designed to provide the maximum draw-off possible for each size tank.

To function satisfactorily, the proper volume of air must be maintained. This is accomplished by the use of an air volume control of the type recommended for use with your pump. Water has the ability to absorb air and unless a means of controlling this is provided, the levels will change the draw-off reducing it until a "water logged tank" condition is reached. See "Water Logged Condition" on page 8.

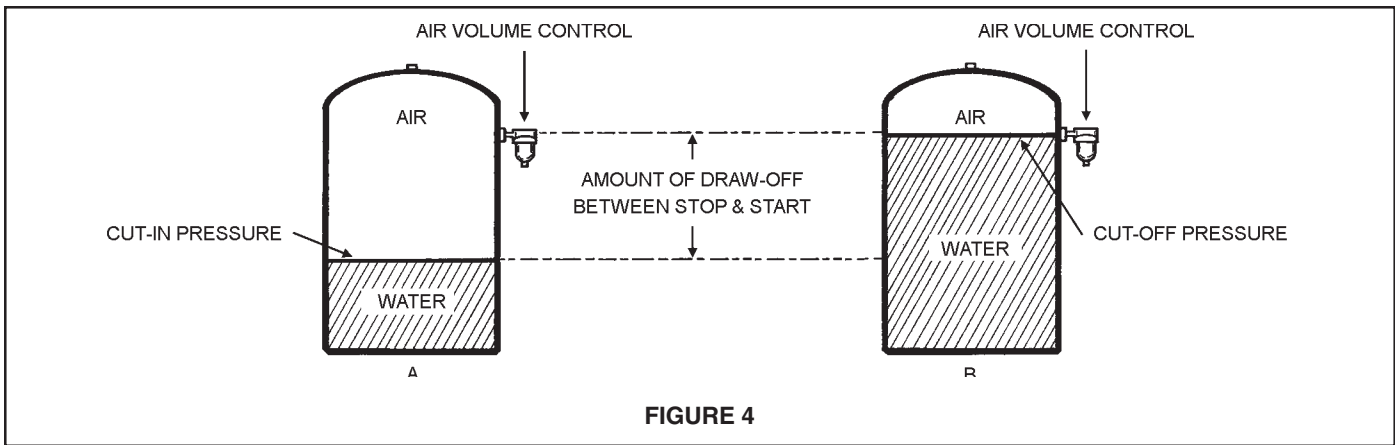

FIGURE 4

WATER LOGGED CONDITION

If draw-down (amount of water that comes out of the tank between pump stops and starts) decreases significantly or the pump starts and stops immediately when water is drawn from the pump tank, this means that the water has absorbed the air volume in the top of the tank.

To avoid such an undesirable condition, which is destructive to the motor, switch, and other equipment, a compressible air volume must be maintained in the upper portion of the tank. Follow these instructions for recharging the air volume.

To Recharge The Air Volume In The Pump Tank:

1. Turn "OFF" electric power to pump.
2. Connect a hose to the drain valve at the pump tank and terminate to an adequate drain.
3. Open a faucet near the pump tank and let the tank drain completely. This will also allow air (atmospheric pressure) to enter into the tank.
4. Close the drain valve at the pump tank.
5. Turn "ON" electric power to pump.
6. With the pump being allowed to run, wait until a steady flow of water is coming from the faucet. This will allow the pump tank to fill with water, capturing a volume of air in the top of the tank.
7. Close the faucet when constant water flow is obtained.

PERIODIC MAINTENANCE

Pressure Relief Valve Operation

The pressure relief valve must be manually operated at least once a year. Failure to install and maintain a new properly listed pressure relief valve could result in serious personal injury, death or property damage.

⚠ **WARNING**

When checking the pressure relief valve; make sure that the water manually discharged will not cause any property damage.

If after manually operating the valve it fails to completely reset and continues to release water, immediately shut off the pump and open a cold water faucet to drain the water out of the pump tank and piping. Then replace the pressure relief valve with a new one (rated at 75 PSI max.).

Turn on electricity to pump and shut off the cold water faucet when water has a steady and constant flow.

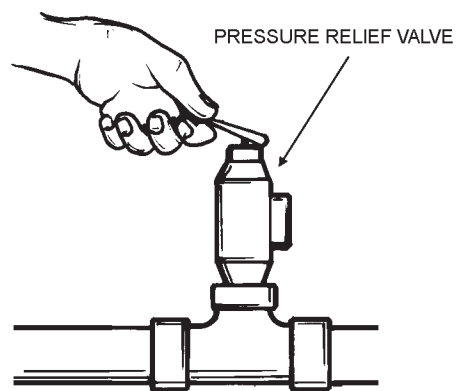

FIGURE 5

Service

If a condition persists or you are uncertain about the operation of the water tank, let a qualified person check it out. Contact a local plumbing contractor.

NOTES:

**FOR THE NAME AND ADDRESS OF THE COMPANY,
REFER TO THE RATING PLATE ON THE WATER TANK.**



RESIDENTIAL PUMP TANK WARRANTY

THIS WARRANTY IS APPLICABLE TO THE ORIGINAL OWNER ONLY. In accordance with the warranty terms and conditions specified below.

3 YEAR LIMITED WARRANTY ON GLASSLINED PUMP TANK AND 1 YEAR LIMITED WARRANTY ON GALVANIZED TANK

The "Company" warrants the pump tank in case of a leak within three (3) years glasslined tank and one (1) year galvanized tank from the date of purchase or, in the absence of a Bill of Sale verifying said date, from the date indicated on the model rating plate affixed to this pump tank.

However, if the use of this pump tank is for commercial, institutional, or industrial purposes, the Company shall limit the maximum duration of this pump tank warranty to one (1) year from date of purchase.

Should a leak occur in the pump tank, the Company will furnish a new current model pump tank of equal capacity and quality. No labor, installation, or freight (if any) charges are included in this warranty. You must pay these costs.

Prior to return of this pump tank to the manufacturer for inspection, the Company will, if requested, ship a replacement pump tank or part C.O.D. and later provide such reimbursement as subsequent inspection indicates is due under these warranties.

CONDITIONS AND EXCEPTIONS

This warranty shall apply only when the pump tank is installed and operated in accordance with 1) all local fire codes and plumbing codes, ordinances and regulations, 2) the printed instructions provided with it, 3) good industry practices, and 4) proper safety practices.

1. THE LIMITED WARRANTIES PROVIDED HEREIN ARE IN LIEU OF ANY AND ALL WARRANTIES, EXPRESS OR IMPLIED, INCLUDING, BUT NOT LIMITED TO, IMPLIED WARRANTIES OF MERCHANTABILITY AND FITNESS FOR A PARTICULAR PURPOSE; PROVIDED, HOWEVER, THAT IMPLIED WARRANTIES ARE NOT DISCLAIMED DURING THE THREE-YEAR PERIOD FROM DATE OF PURCHASE.
2. THE COMPANY SHALL HAVE NO LIABILITY HEREUNDER, EITHER DIRECT OR CONTINGENT,

FOR INCIDENTAL OR CONSEQUENTIAL DAMAGES. SOME STATES DO NOT ALLOW THE EXCLUSION OR LIMITATION OF INCIDENTAL OR CONSEQUENTIAL DAMAGES.

3. This warranty gives you specific legal rights. If any provision of this warranty is prohibited or invalid under applicable state law, that provision shall be ineffective to the extent of the prohibition or invalidity without invalidating the remainder of the affected provision or the other provisions of this warranty.

Should governmental regulations or industry standards prohibit the Manufacturer from furnishing a comparable model replacement under this warranty, the Owner will be furnished with the closest comparable pump tank meeting the then current governmental regulations and industry standards. A supplementary fee may be assessed to cover the additional cost associated with the changes made to meet applicable regulations and standards.

4. Any accident to the pump tank or any part thereof (including freezing, fire, floods, or lightning), any misuse, abuse or alteration of it, any operation of it in a modified form, or any damage caused by attempts to repair tank leaks, will void this warranty.
 - a. If the design or structure of the pump tank is, or is attempted to be, modified or altered in any way, including, but not limited to, by attaching non-Company approved appliances or equipment.
 - b. If the pump tank is not operated within the factory calibrated temperature limits.
 - c. If leaks in the pump tank, or defects in other parts, arise as the result of improper use, negligence in operation, or accident, or inability of the unit to function because of repairs, adjustments, or replacements improperly made outside the Company's factory, or because of fire, floods or lightning.
 - d. If leaks in the pump tank arise as a result of puncture by screws or other pointed objects used during installation or servicing of the unit.
 - e. If the rating plate has been defaced or discarded and you do not have a Bill of Sale to verify the purchase date.

5. Replacements and/or repairs furnished under these warranties do not carry a new warranty, only the unexpired portion of the original warranty.
6. In order to obtain service under these warranties you must promptly notify the installing contractor or dealer, giving the nature of the problem and the model and serial number of the pump tank. If for any reason the installer or dealer cannot be located or fails to provide satisfactory warranty service, you should write the Company with the above information.
7. This warranty does not apply to connecting tubing installed external to the unit, nor to the joints or connections of said tubing to the unit.
8. The terms of this warranty may not be varied by any person, whether or not purporting to represent or to act on behalf of the Company.
9. Any claim under this warranty should be initiated with the dealer who sold the pump tank, or with any other

dealer handling the warrantor's products. If this is not practical, the owner should contact the company.

IMPORTANT INFORMATION

Model Number: _____

Serial Number: _____

INSTALLATION INFORMATION

Date Installed: _____

Company's Name: _____

Street or P.O. Box: _____

City, State, and Zip Code: _____

Phone Number: _____

Plumber's Name: _____

